

Our Range and Types of Deliveries

SHAPE	D DIAMETER	T WIDTH	H BORE	P RECESS	S SHAFT	L LENGTH	E HEIGHT OF BASE
	Min. – max.	Min. – max.	Min. – max.	Min. – max.	Min. – max.	Min. – max.	Min. – max.
Full material cup wheel	75 – 170 mm	25 – 60 mm	9 – 100 mm	60 – 125 mm	–	–	5 – 19 mm
Cup wheel with plate	75 – 170 mm	25 – 60 mm	9 – 100 mm	60 – 125 mm	–	–	5 – 19 mm
Peripheral wheel	20 – 300 mm	6 – 60 mm	6 – 130 mm	–	–	–	–
Sleeve	15 – 30 mm	6 – 12 mm	5 – 30 mm	–	–	–	–
Mounted point	8 – 30 mm	5 – 30 mm	–	–	3 – 8 mm	40 – 120 mm	–

We provide peripheral wheels, cup wheels, rings, sleeves and points as well as the most varied special shapes according to your special requirements. Segmenting of full material cup wheels and cup wheels with plate can be realised just as special cooling bore holes. Please contact us!

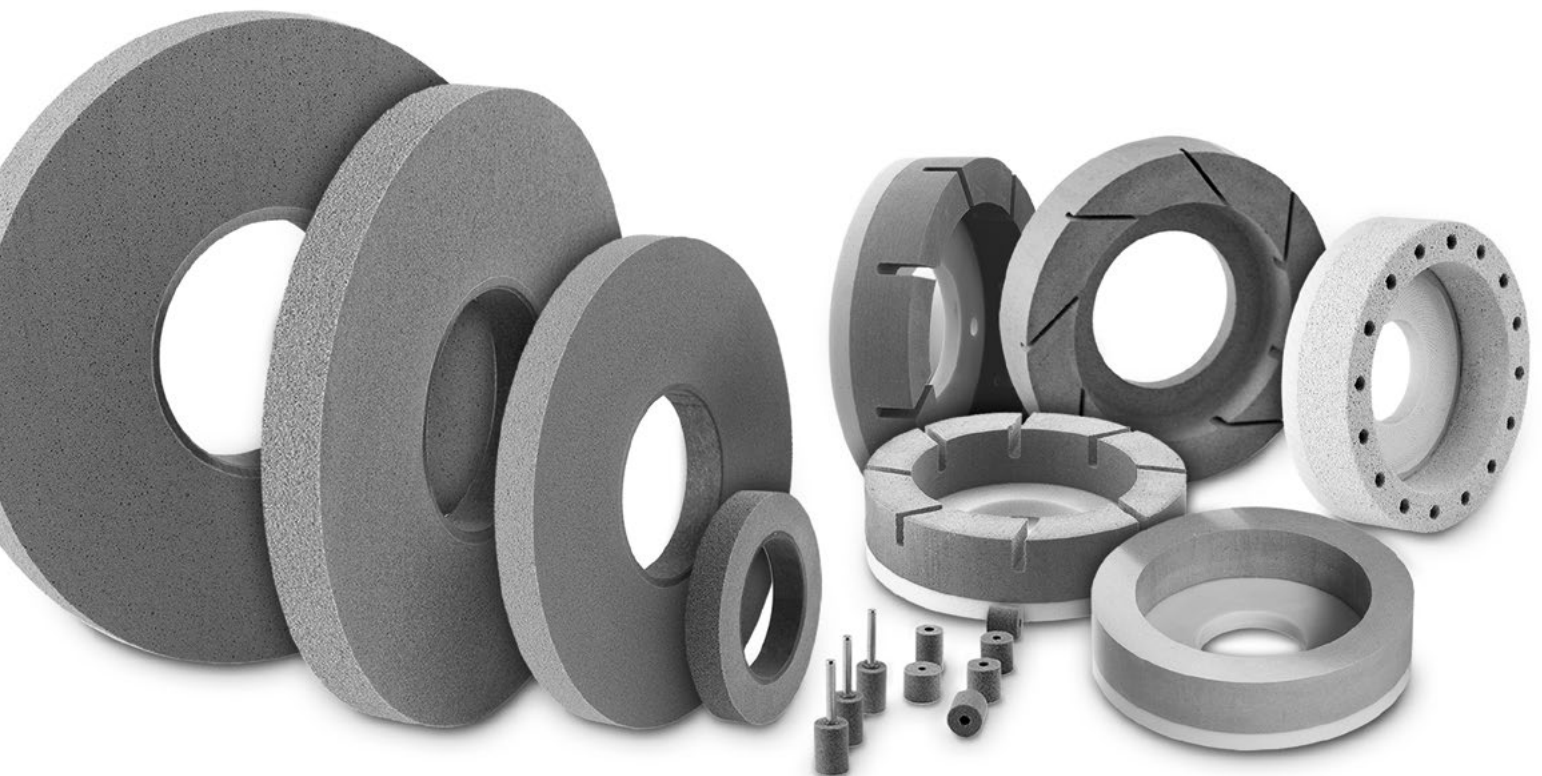

FULL MATERIAL CUP WHEEL

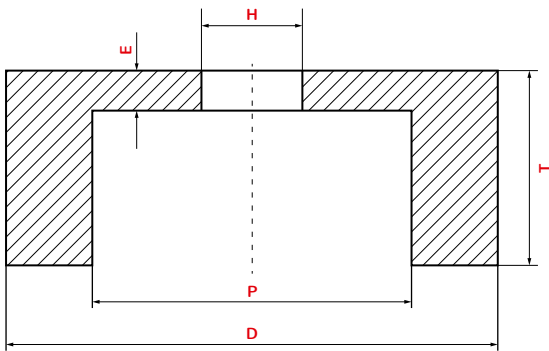

CUP WHEEL WITH PLATE

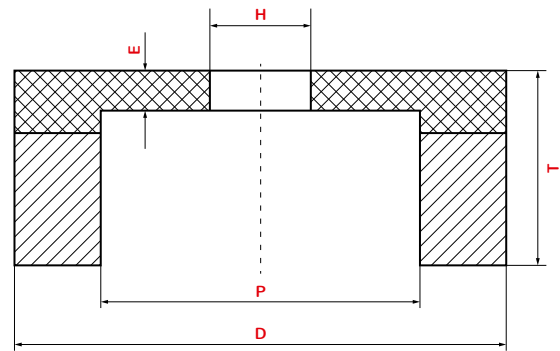

PERIPHERAL WHEEL

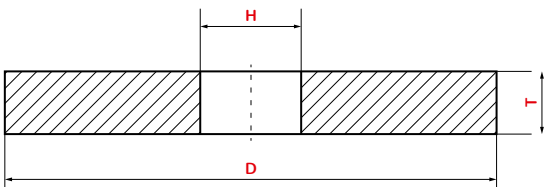

MOUNTED POINT

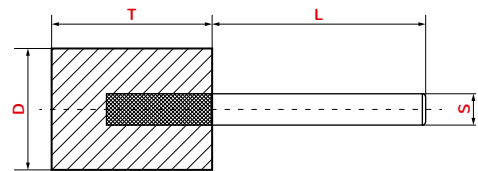

SLEEVE

